

# FICHE D'HOMOLOGATION HOMOLOGATION FORM



## COMMISSION INTERNATIONALE DE KARTING - FIA



### MOTEUR / ENGINE KZ

Constructeur	<i>Manufacturer</i>	<b>TM RACING S.P.A.</b>
Marque	<i>Make</i>	<b>TM RACING</b>
Modèle	<i>Model</i>	<b>KZ10C</b>
Type d'admission	<i>Inlet type</i>	<b>REED VALVE</b>
Durée de l'homologation	<i>Validity of the homologation</i>	9 ans / 9 years
Nombre de pages	<i>Number of pages</i>	<b>10</b>

La présente Fiche d'Homologation reproduit descriptions, illustrations et dimensions du moteur au moment de l'homologation CIK-FIA. Le Constructeur a la possibilité de les modifier seulement dans les limites fixées par le Règlement CIK-FIA en vigueur. La hauteur du moteur complet sur les photos doit être de 7cm minimum.

*This Homologation Form reproduces descriptions, illustrations and dimensions of the engine at the moment of the CIK-FIA homologation. The Manufacturer may modify them, but only within the limits fixed by the CIK-FIA Regulations in force. The height of complete engines on all photos must be minimum 7cm.*

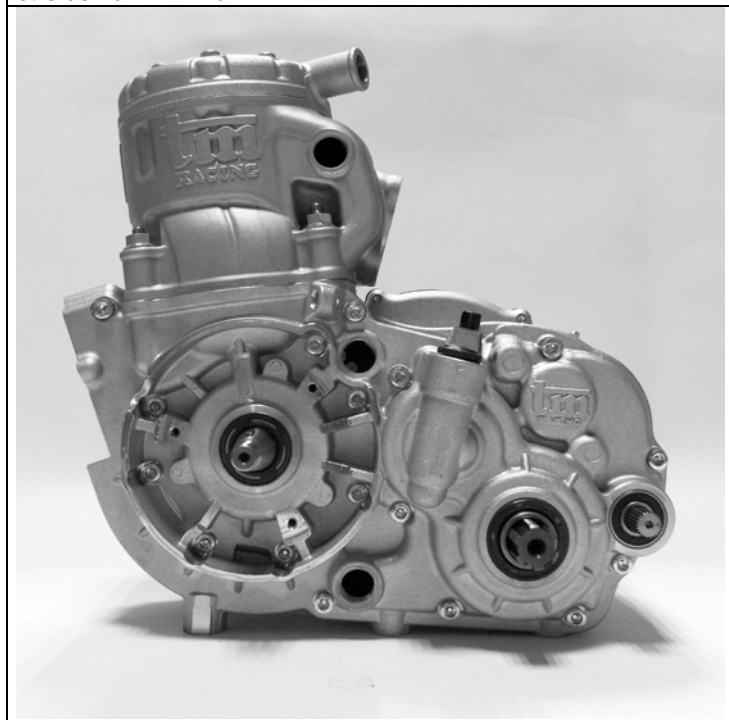

PHOTO DU MOTEUR CÔTÉ PIGNON  
PHOTO OF DRIVE SIDE OF ENGINE

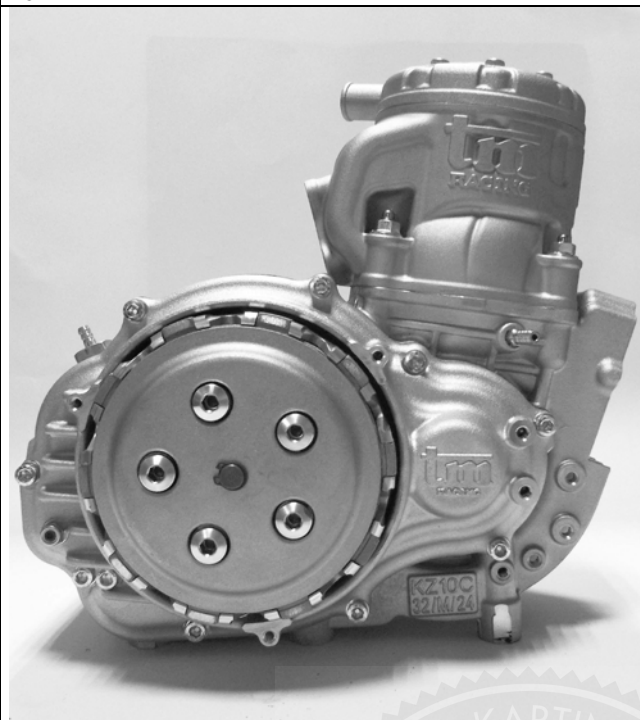

PHOTO DU MOTEUR CÔTÉ OPPOSÉ  
PHOTO OF OPPOSITE SIDE OF ENGINE

Signature et tampon de l'ASN  
*Signature and stamp of the ASN*



Signature et tampon de la CIK-FIA  
*Signature and stamp of the CIK-FIA*



INFORMATIONS TECHNIQUES		TECHNICAL INFORMATION	
A	CARACTÉRISTIQUES	A	CHARACTERISTICS
			Tolérances
Volume du cylindre	<i>Volume of cylinder</i>	<b>124.66 CM3</b>	<b>&lt; 125cm<sup>3</sup></b>
Alésage d'origine	<i>Original Bore</i>	<b>54 MM</b>	
Alésage théorique maximum	<i>Theoretical maximum bore</i>	<b>54.07 MM</b>	
Course	<i>Stroke</i>	<b>54.43 MM</b>	
Système de refroidissement	<i>Cooling system</i>	<b>WATER</b>	
Nombre de systèmes de carburation	<i>Number of carburation systems</i>	<b>1 CARBURETOR</b>	
Nombre de canaux de transfert, cylindre/carter	<i>Number of transfer ducts, cylinder/sump</i>	<b>5/3</b>	
Nombre de lumières / canaux d'échappement	<i>Number of exhaust ports / ducts</i>	<b>3</b>	
Forme de la chambre de combustion	<i>Shape of the combustion chamber</i>	<b>SPHERIC WITH VARIABLE RADIUS+SQUISH</b>	
Matériau de la paroi du cylindre	<i>Cylinder wall material</i>	<b>ALUMINIUM ALLOY+ NICASIL</b>	
Longueur (entre-axe) de la bielle	<i>Length between the axes of the connecting rod</i>	<b>109.8</b>	±0.1mm
Volume de la chambre de combustion	<i>Volume of combustion chamber</i>	<b>11 CC</b>	Minimum
Nombre de segments de piston	<i>Number of piston rings</i>	<b>1 OR 2</b>	
Modifications autorisées selon le Règlement Technique. Seules les dimensions et cotes qui ne peuvent pas être modifiées doivent figurer sur la Fiche d'Homologation.			
Modification allowed according to the Technical Regulations. Only the dimensions and readings which may not be changed must be mentioned on the Homologation Form.			

B	ANGLES D'OUVERTURE	B	OPENING ANGLES
De l'échappement	<i>Exhaust</i>		According to the Regulations

C	MATÉRIAU	C	MATERIAL
Cylindre	<i>Cylinder</i>		<b>ALUMINIUM ALLOY+NICASIL</b>
Culasse	<i>Cylinder head</i>		<b>ALUMINIUM ALLOY</b>
Carter	<i>Sump</i>		<b>ALUMINIUM ALLOY</b>
Bielle	<i>Connecting rod</i>		<b>STEEL</b>

DESSIN DU DÉVELOPPEMENT DU CYLINDRE

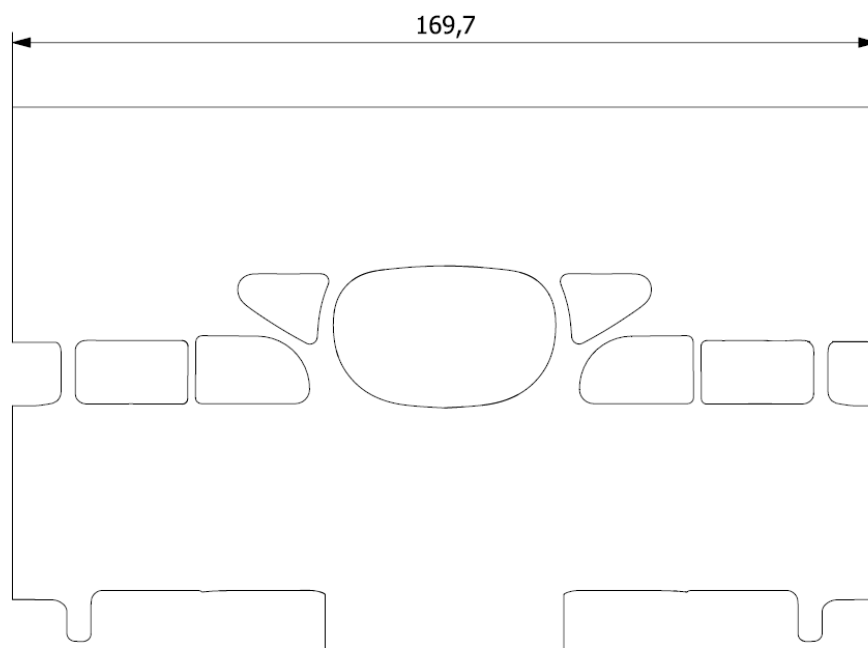
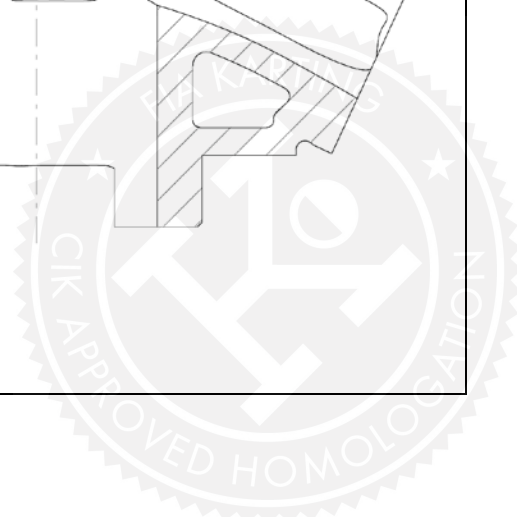
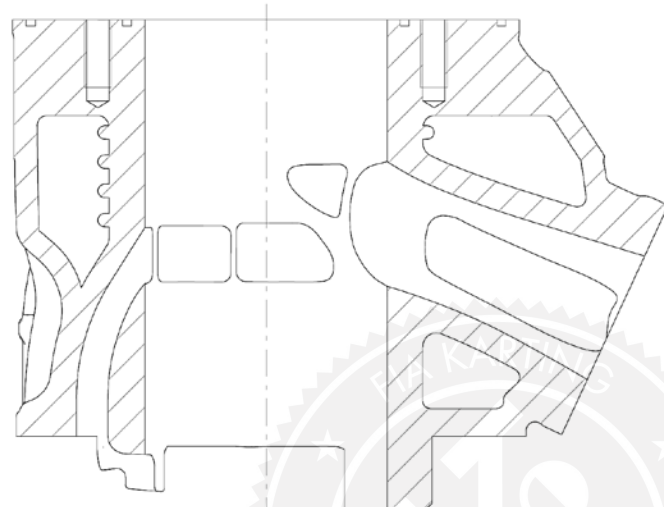
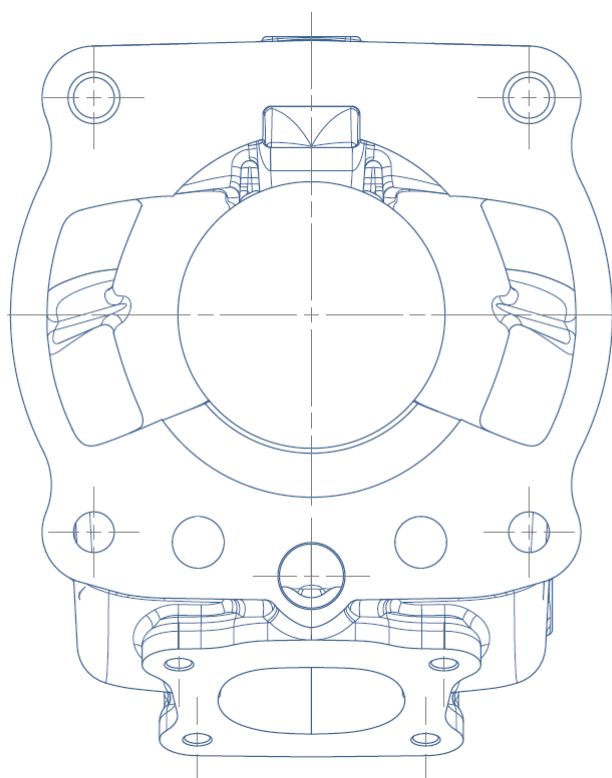
*DRAWING OF THE CYLINDER DEVELOPMENT*DESSIN DU PIED DU  
CYLINDRE*DRAWING OF THE  
CYLINDER BASE*VUE EN SECTION DU  
CYLINDRE*SECTION VIEW OF  
CYLINDER*

**32/M/24**

DESSIN DE LA CULASSE ET DE LA CHAMBRE  
DE COMBUSTION

*DRAWING OF THE CYLINDER HEAD AND OF  
THE COMBUSTION CHAMBER*

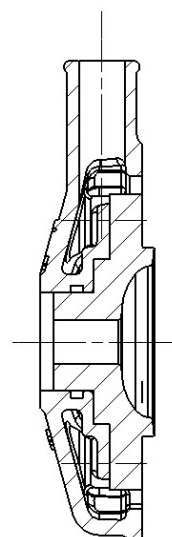
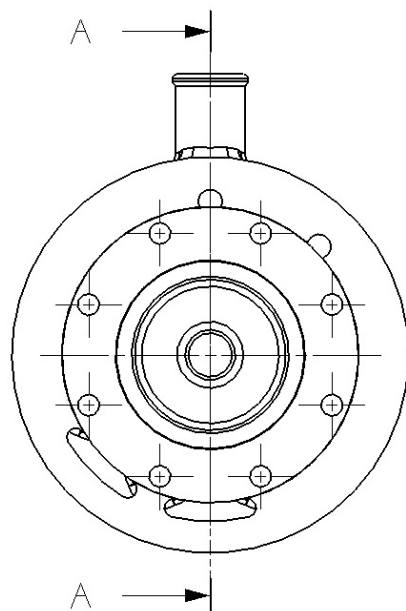

SECTION A - A

DESSIN DU  
VILEBREQUIN

*DRAWING OF THE  
CRANKSHAFT*

DESSIN INTÉRIEUR  
DU CARTER

*DRAWING OF THE  
INSIDE OF SUMP*

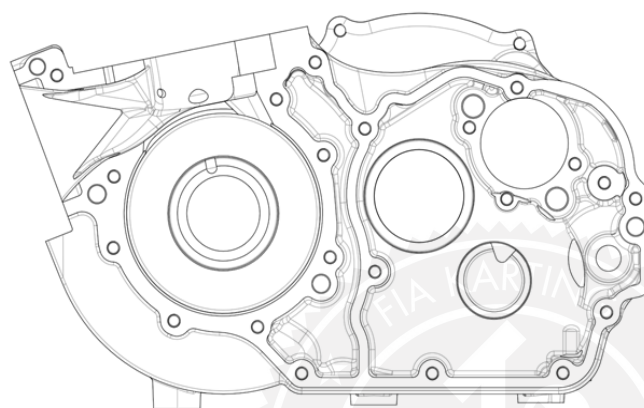
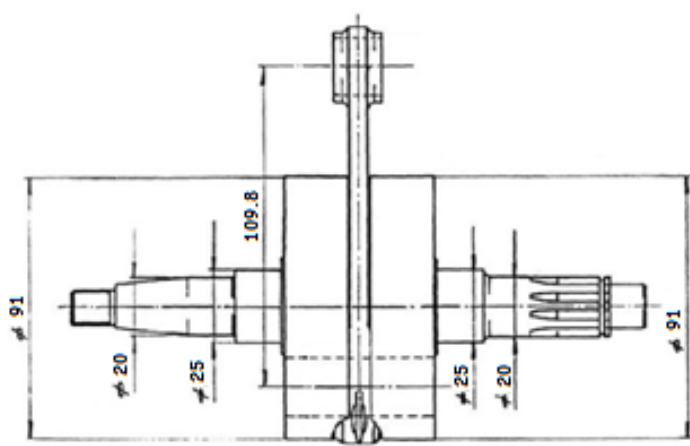

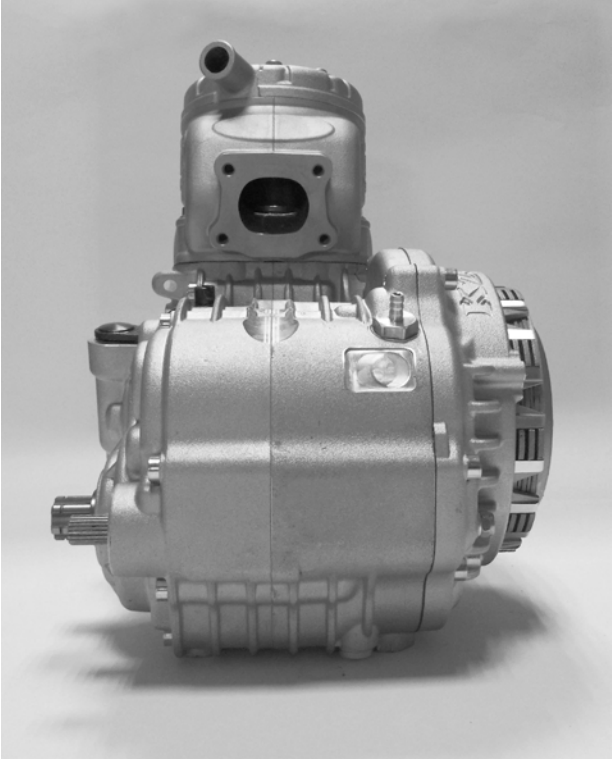
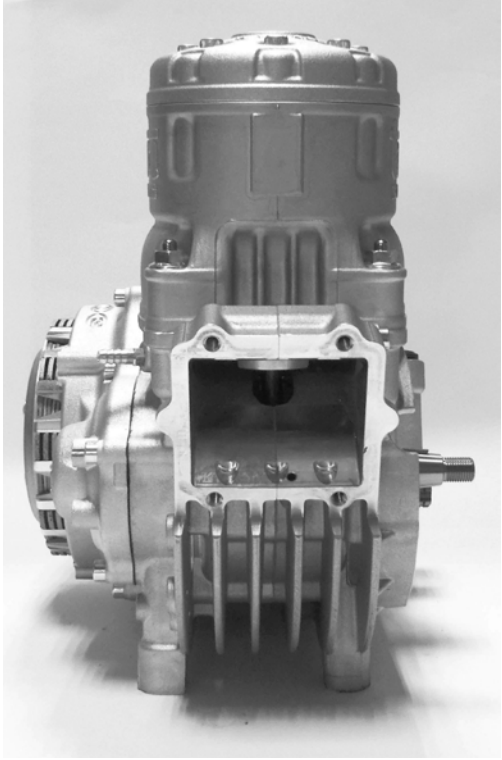
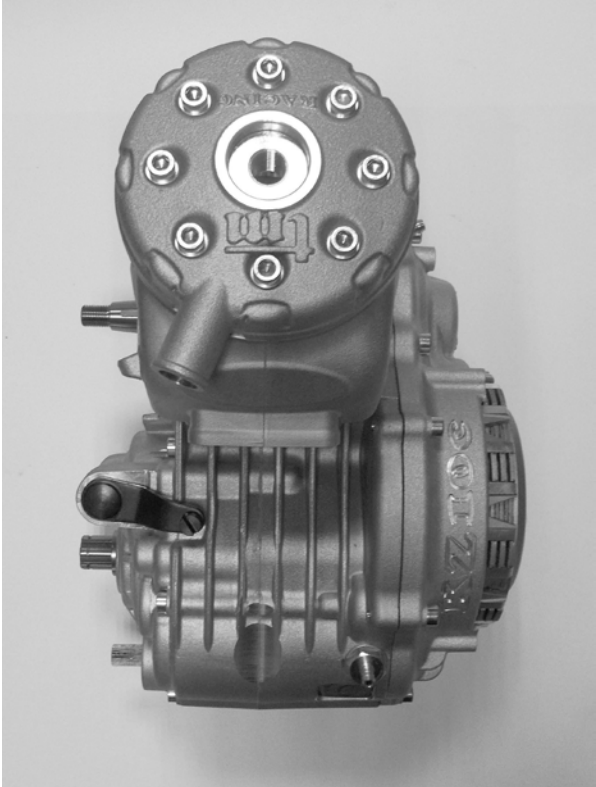
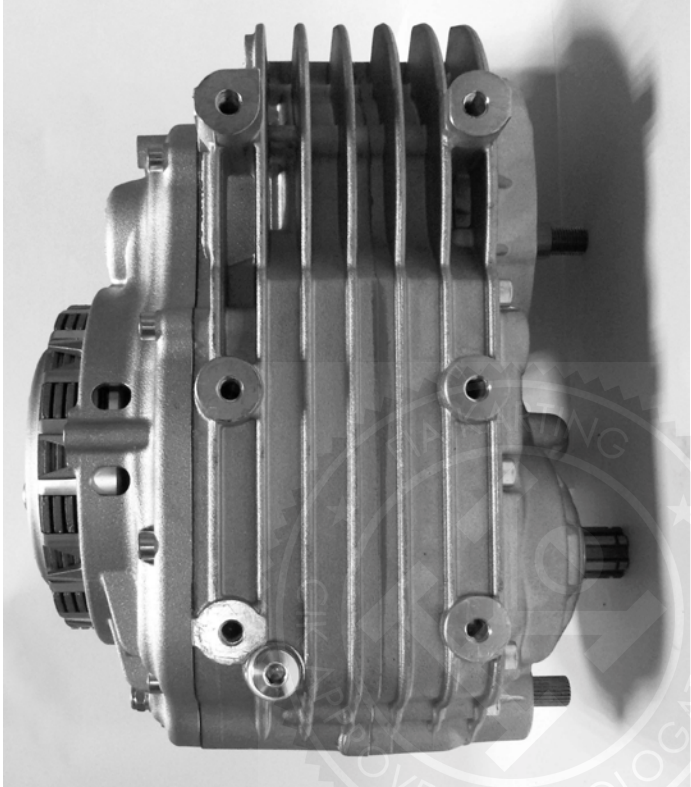
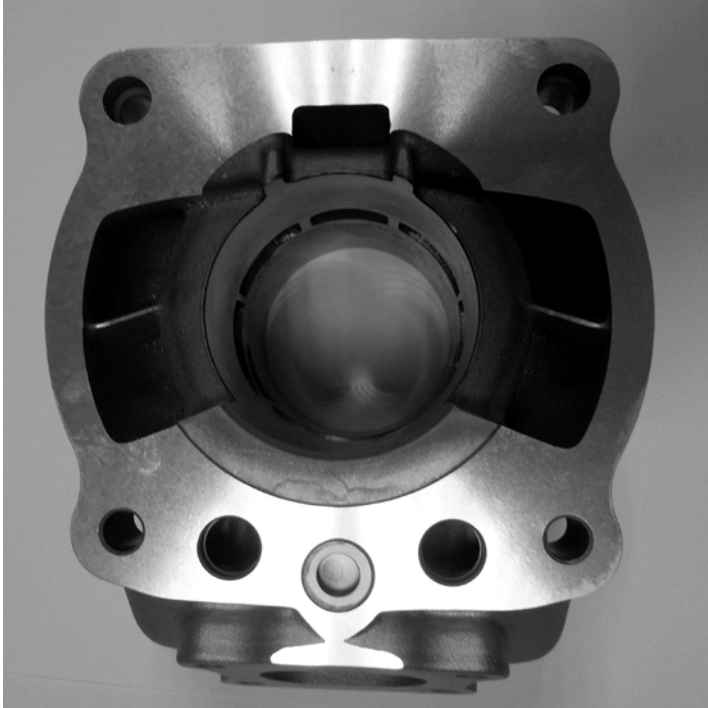

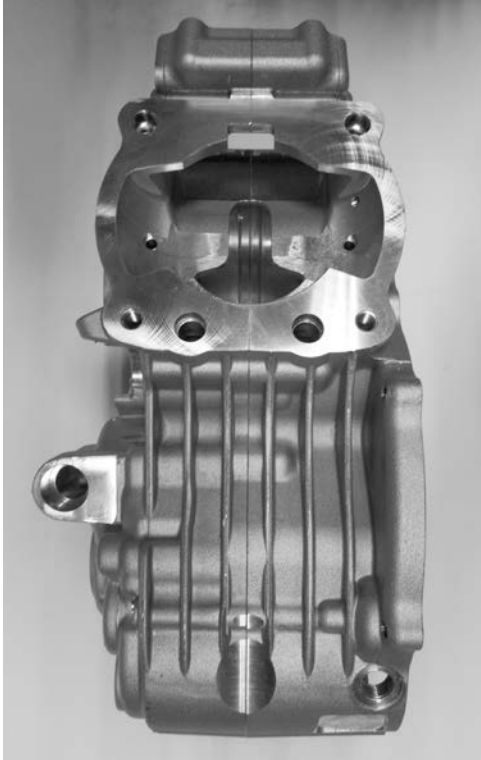

PHOTO DE L'ARRIÈRE DU MOTEUR	<i>PHOTO OF THE BACK OF THE ENGINE</i>	PHOTO DE L'AVANT DU MOTEUR	<i>PHOTO OF THE FRONT OF ENGINE</i>
			
PHOTO DU MOTEUR PARTIE SUPÉRIEURE	<i>PHOTO OF THE ENGINE TAKEN FROM ABOVE</i>	PHOTO DU MOTEUR PARTIE INFÉRIEURE	<i>PHOTO OF THE ENGINE TAKEN FROM BELOW</i>
			

PHOTO DU PIED DU CYLINDRE	PHOTO OF THE BASE OF THE CYLINDER	PHOTO DE LA CHAMBRE DE COMBUSTION	PHOTO OF COMBUSTION CHAMBER
			
PHOTO DU CARTER ( CÔTÉ JOINT )	PHOTO OF THE SUMP ( GASKET FACE )	PHOTO D'UNE PARTIE INTÉRIEURE DU CARTER	PHOTO OF AN INTERNAL PART OF THE SUMP
			

**32/M/24**

DESSIN DE LA BOÎTE À CLAPETS

DRAWING OF REED VALVE

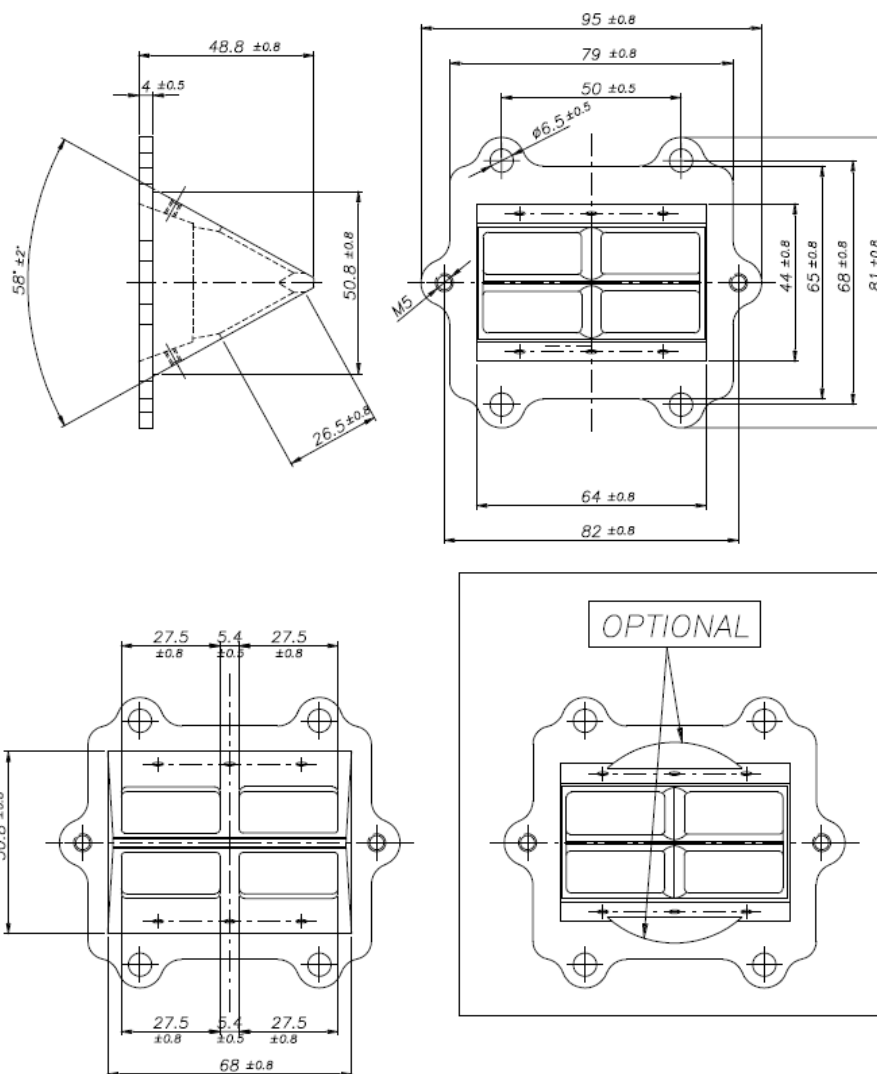

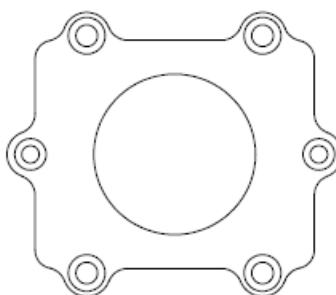

DESSIN DU COUVERCLE DE LA BOÎTE À CLAPETS

DRAWING OF REED VALVE COVER



BOÎTE DE VITESSES		GEARBOX	
Couple primaire		<i>Primary coupling</i>	
		<b>19/75</b>	
Rapports de boîte de vitesses		<i>Gearbox ratios</i>	
Vitesse	Arbre primaire	Arbre secondaire	Relevé des valeurs obtenues après trois tours moteur
<i>Gear</i>	<i>Primary shaft</i>	<i>Secondary shaft</i>	<i>Reading of values obtained after three engine revs</i>
1 <sup>ère</sup> /1 <sup>st</sup>	<b>13</b>	<b>33</b>	<b>107.8°</b>
2 <sup>e</sup> /2 <sup>nd</sup>	<b>16</b>	<b>29</b>	<b>151.0°</b>
3 <sup>e</sup> /3 <sup>rd</sup>	<b>18</b>	<b>27</b>	<b>182.4°</b>
4 <sup>e</sup> /4 <sup>th</sup>	<b>22</b>	<b>27</b>	<b>222.9°</b>
5 <sup>e</sup> /5 <sup>th</sup>	<b>22</b>	<b>23</b>	<b>261.7°</b>
6 <sup>e</sup> /6 <sup>th</sup>	<b>27</b>	<b>25</b>	<b>295.5°</b>

PHOTOS DE L'ÉCHAPPEMENT	PHOTOS OF THE EXHAUST
	



DESCRIPTIONS TECHNIQUES		TECHNICAL DESCRIPTIONS	
Poids en gr		Weight in gr	<b>1065</b>
Volume in cm <sup>3</sup>		Volume in cc	<b>4012</b>
			Minimum +/-5 %

DESSINS TECHNIQUES	TECHNICAL DRAWINGS
Contenant toutes les informations permettant de construire cet échappement.	Including all the information necessary to build this exhaust.

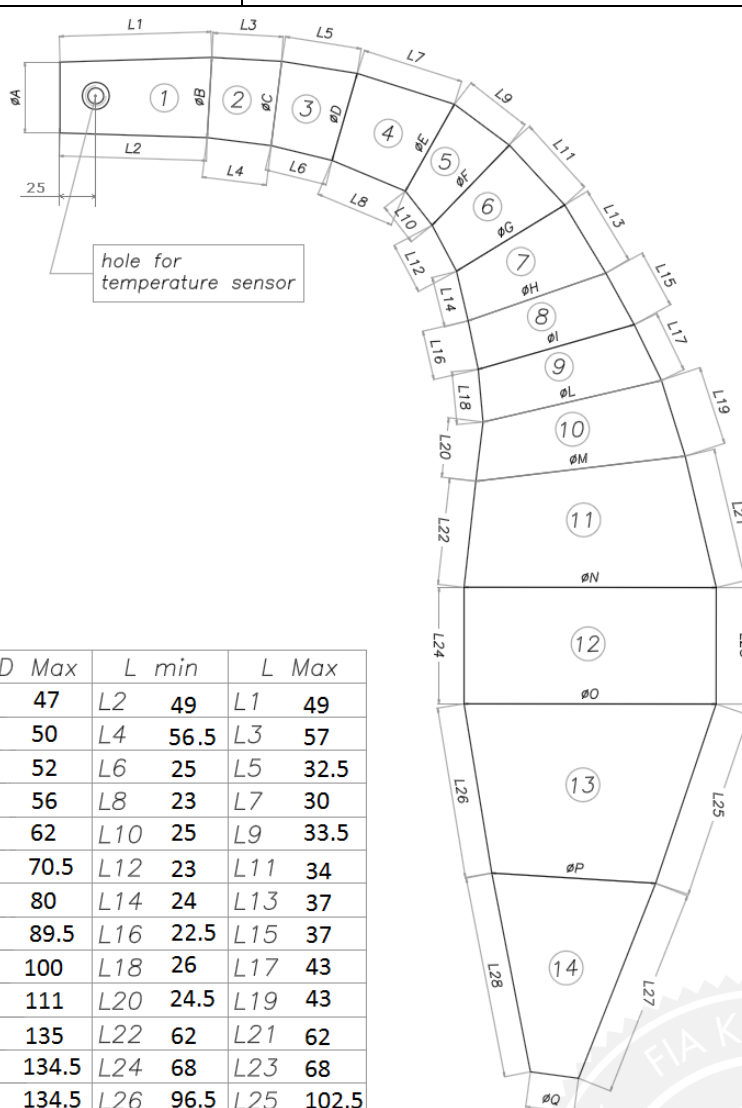

PARTE	$D$ min	$D$ Max	$L$ min	$L$ Max
1	øA 44.5	øB 47	L2 49	L1 49
2	øB 47	øC 50	L4 56.5	L3 57
3	øC 50	øD 52	L6 25	L5 32.5
4	øD 52	øE 56	L8 23	L7 30
5	øE 56	øF 62	L10 25	L9 33.5
6	øF 62	øG 70.5	L12 23	L11 34
7	øG 70.5	øH 80	L14 24	L13 37
8	øH 80	øI 89.5	L16 22.5	L15 37
9	øI 89.5	øL 100	L18 26	L17 43
10	øL 100	øM 111	L20 24.5	L19 43
11	øM 111	øN 135	L22 62	L21 62
12	øN 135	øO 134.5	L24 68	L23 68
13	øP 82.7	øO 134.5	L26 96.5	L25 102.5
14	øQ 26	øP 82.7	L28 98	L27 109

COUVERCLE D'EMBRAYAGE (OPTION)

CLUTCH COVER (OPTIONAL)

